

**SLH Series Jet Mud Mixer**

**SLH series Jet mud mixer**

Model	SLH150-50	SLH150-40	SLH150-35	SLH100
Matching Pump	SB8×6-13(55kw)	SB6×5-13(45kw)	SB5×4-13(30kw)	SB4×3-11(15kw)
Capacity	240m <sup>3</sup> /h(1056GPM)	180m <sup>3</sup> /h(792GPM)	120m <sup>3</sup> /h(528GPM)	60m <sup>3</sup> /h(264GPM)
Pressure	0.25~0.40Mpa	0.25~0.40Mpa	0.25~0.40Mpa	0.25~0.40Mpa
Inlet	150mm	150mm	150mm	100mm
Nozzle caliber	50mm	40mm	35mm	30mm
Hopper dimension	750×750mm	750×750mm	600×600mm	500×500mm
Burden speed	≤100kg/min	≤80kg/min	≤60kg/min	≤40kg/min
Density	≤2.8g/cm <sup>3</sup>	≤2.4g/cm <sup>3</sup>	≤2.0g/cm <sup>3</sup>	≤1.5g/cm <sup>3</sup>
Viscosity	≤120s	≤120s	≤80s	≤60s

**Oil Drilling&HDD**

Mud Solids Control Specialist



**SLH150-50/40/35 Jet Mud mixer drawing**

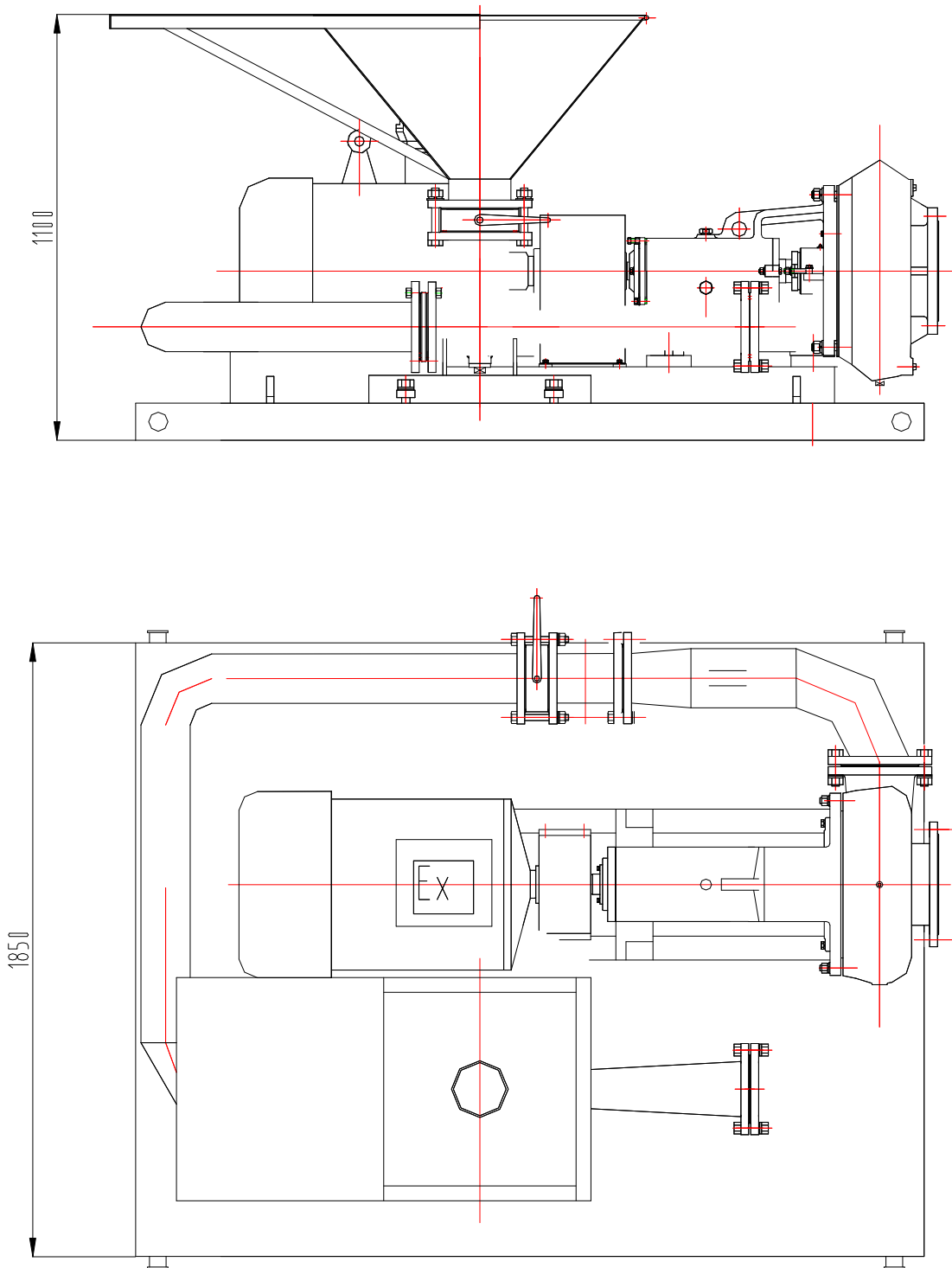

**Dimensions:2200L×1850W×1100H**

**SLH100 Jet Mud mixer drawing**

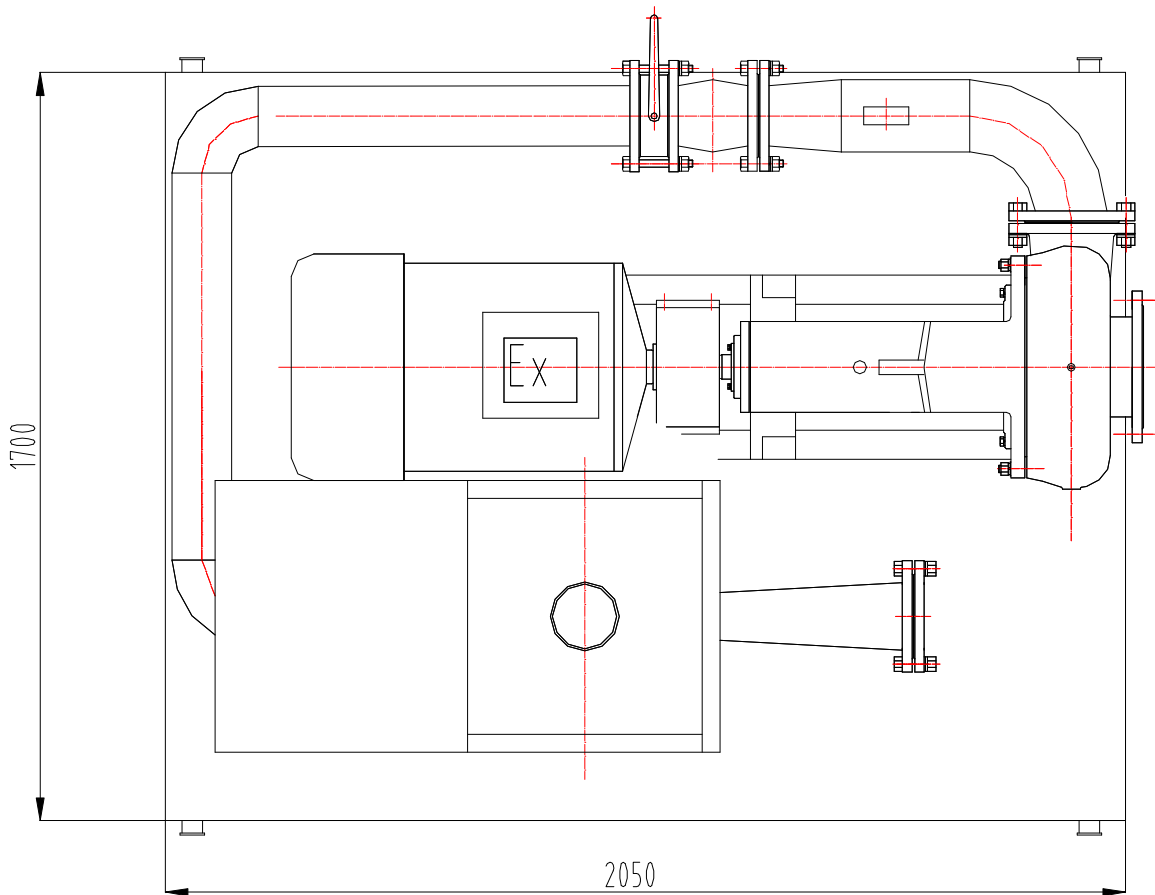
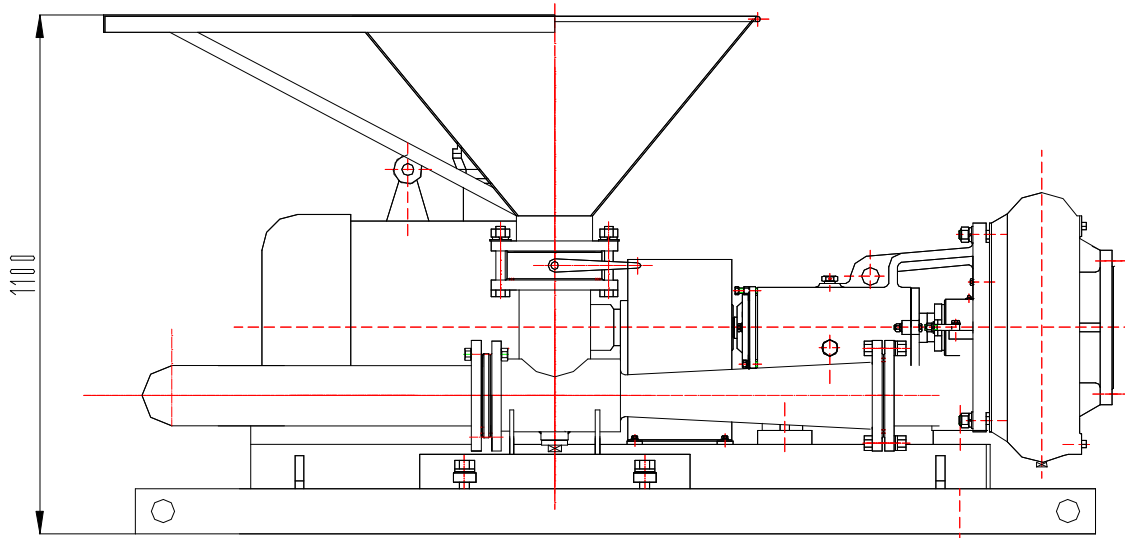

**Dimensions: 2050L × 1700W × 1100H**

**Matching Pump Specs****SB series Sand Pump**

Model	Flow	Lift	Power	Speed	Efficiency
SB8×6-14	320m <sup>3</sup> /h	40m	75KW	1450r/min	65%
SB8×6-13	290m <sup>3</sup> /h	35m	55KW	1450r/min	64%
SB8×6-12	270m <sup>3</sup> /h	28m	45KW	1450r/min	64%
SB6×5-14	200m <sup>3</sup> /h	40m	55KW	1450r/min	62%
SB6×5-13	180m <sup>3</sup> /h	35m	45KW	1450r/min	60%
SB6×5-12	160m <sup>3</sup> /h	30m	37KW	1450r/min	62%
SB5×4-14	120m <sup>3</sup> /h	40m	37KW	1450r/min	56%
SB5×4-13	90m <sup>3</sup> /h	40m	30KW	1450r/min	56%
SB4×3-13	60 m <sup>3</sup> /h	27m	15 KW	1450r/min	51%
SB4×3-12	60m <sup>3</sup> /h	20m	11KW	1450r/min	54%
SB4×3-11	40m <sup>3</sup> /h	20m	7.5KW	1450r/min	49%
SB3×2-13	32.5 m <sup>3</sup> /h	31m	11 KW	1450r/min	39%
SB3×2-11	30m <sup>3</sup> /h	23m	7.5 KW	1450r/min	42%

**Oil Drilling&HDD**

Mud Solids Control Specialist

**Contact:**

Company name: Tangshan Guanneng Machinery Equipment Co.ltd

HQ Address: No.166 West Ringroad, Tangshan, China 063000

Tel: +86-315-7062282 +86-315-8082667

Fax: +86-315-5281600 +86-315-5281900

Email: [Sales@gnsolidscontrol.com](mailto:Sales@gnsolidscontrol.com)Website: <http://www.gnsolidscontrol.com> (English)